

COMMAND & CONTROL CENTER
P/N: 1500047

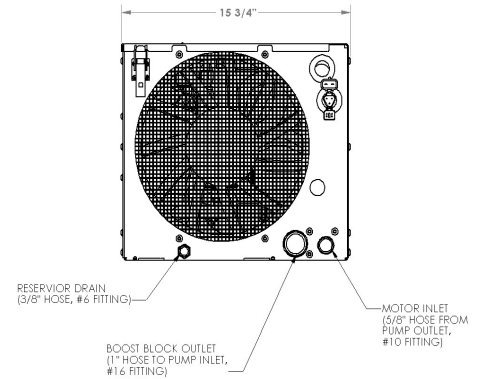
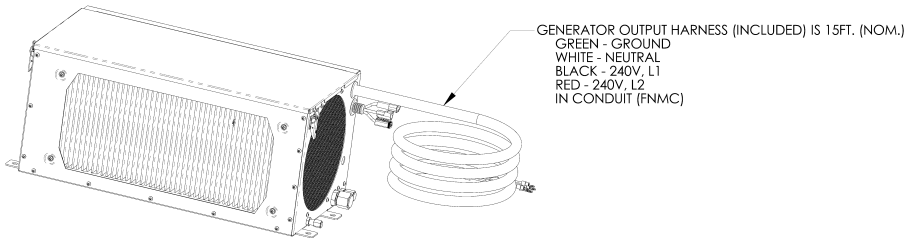
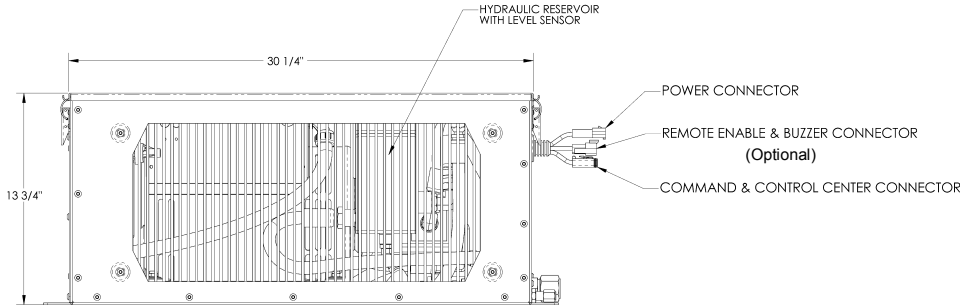

Smart Power System Specifications

Model number:	LR-6	LR-8
Part number:	1700806	1700808
Power:	6.2kW	8kW
AC amps:	52/26	67/34
Continuous watts:	6200	8000
Peak watts:	7500	9000
Tray weight:	208 lb.	217 lb.
Power take off:	Chelsea 249 (Diesel) 247 (Gas)	Chelsea 249 (Diesel) 247 (Gas)
Hydraulic pump:	23cc PTO with integrated gear pump	23cc PTO with integrated gear pump
Pump rotation:	Left hand	Left hand
AC volts:	120/240 VAC (re-connectable to 120 VAC only)	
Frequency:	60 Hertz	
Phase:	Single	
Generator speed:	3600 RPM	
Frame size:	30.25" L x 15.75" W x 13.75" H	
Reservoir:	Integrated within tray	
Hydraulic pump type:	Gear pump—Attached to PTO	
PSI:	400 to 3600	
GPM:	10	
Required engine speed:	1300-1500 RPM fixed engine speed	
Filtration:	10 Micron	
Fluid:	Dexron III	

Light Rescue Series (Ford 250, 350, 450, 550 & 650 chassis)

Compact, all solid-state, electronic controlled Hydraulic Generators

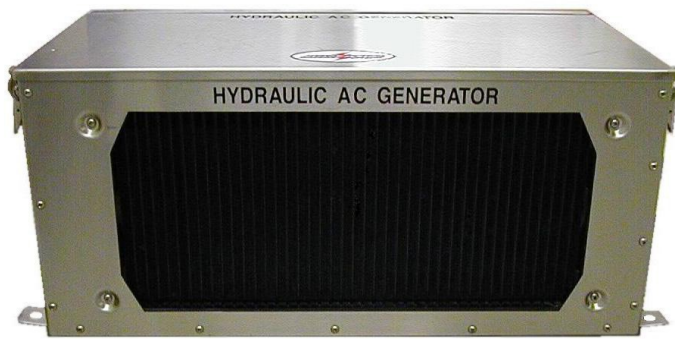

Smart Power Systems® severe-duty, electronic controlled generator systems are designed to meet the most demanding mobile applications, and provide 120VAC/240VAC, 60Hz clean power. The cleanest power available of any hydraulic generator.

Their (1) reliability, (2) compact 1 piece module, and (3) proven field performance make Smart Power the *first choice* for fire fighters.

Smart Power Systems® provides

Instant power you can rely on

- Trouble free GENSET operation and maintenance
- Generator 100% system tested with pump prior to shipment
- Mounts on light duty trucks; compartment, top, etc.
- Fits all 4X2, 4X4 configurations with 5R110–6R140 TorqShift transmission
- Rugged, stainless steel, fully enclosed 1 piece module
- Unique “super cooled” power generation for continuous 120 °F operation
- Solid state system controller provides total control
- Smart Start* power engagement reduces stress on PTO and truck powertrain



Compact size

- System includes a heavy-duty Chelsea PTO
- Drop-in field replacement
- Smallest industry footprint saves valuable space for other gear/equipment
- Common hookups for all models

Ease of operation

- Command & Control Center continuously monitors system and optimizes overall performance
- Smart Touch® sealed touch pads provide operator interactive capabilities; manual override/control.
- Integrated diagnostics and service advisories
- Service intervals of 250 hours or 3 years

Superior warranty protection

- 6 years/1000 hours—Includes PTO pump and Command and Control Center
- The total generator system is factory tested and Certified.

Outstanding technical support

- Large experienced technical support staff
- Over 45 years manufacturing expertise
- 165,000 square ft. state-of-the-art facility is ISO9001/2008 certified



Smart Power Systems®

5000 North US-131 • Reed City, MI 49677
(231) 832-5525 • fax: (231) 832-3876 • sales@smartpower.com
Smart Power Systems® and Smart Touch® are Nartron registered trademarks
TECHNICAL HOTLINE: (231) 680-4274

*patents 5,087,825; 5,796,183; 7,053,498; 7,459,800; 7,759,811; 8,269,359; 8,269,360; 8,626,384; DE19703404 and others pending