

Light Rescue Series (GM 2500, 3500, 4500, 5500, 6500, 7500)

Compact, all solid-state, electronic controlled Hydraulic Generators

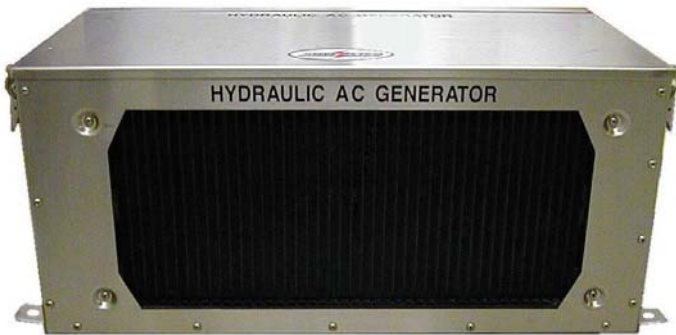

Smart Power® Systems severe-duty, 1 piece, electronic controlled generator systems are designed to meet the most demanding mobile applications, and provide 120VAC/240VAC, 60Hz clean power. The cleanest power available.

Their (1) reliability, (2) compact 1 piece module, (3) clean power, and (4) proven field performance make them the *first choice* for fire fighters.

smart power® provides

Instant power you can rely on

- Trouble free GENSET operation and maintenance
- Generator 100% system tested prior to shipment
- Mounts on light duty trucks; compartment, top, etc.
- Rugged, stainless steel, fully enclosed 1 piece module
- Solid state system controller; provides total control
- Fits all 4X2, 4X4 configurations with 6.6L Duramax engine, 8.1L gas or CAT 3126
- Unique “super cooled” power generation for continuous 120°F operation
- Solid state system controller provides total control; optional multiplexing interface (J1939)
- Smart Start* power engagement reduces stress on generator and truck powertrain



Compact size

- System includes a complete engine mount bracket/clutch/pump kit
- 1 piece GENSET module includes integrated hydraulic fluid reservoir
- Single piece drop-in field replacement (replaces all genset brands)
- Smallest industry footprint saves valuable space for other gear/apparatus
- Common hookups for all models

Ease of operation

- Command & Control Center continuously monitors system and optimizes overall performance
- Smart Touch® sealed touch pads provide operator interactive capabilities; manual override/control
- Integrated diagnostics and service advisories
- Service intervals of 250 hours or 3 years

Superior warranty protection

- 5 years/1000 hours
- The total system is factory tested and Certified

Outstanding technical support

- Large experienced technical support staff
- 37 years manufacturing expertise
- 200,000 square ft. state-of-the-art facilities
-  Approved, QS-9000, ISO 9001, meets/exceeds all NEMA, IEEE, NFPA, MIL ISO 9001, ASA requirements



*pats.pending

Smart Power Systems

5000 North US-131 • Reed City, MI 49677

(231) 832-5525 • fax: (231) 832-3876 • sales@smartpower.com

Smart Power®, Smart Touch®, sense-compute-control® are registered trademarks of Nartron Corporation

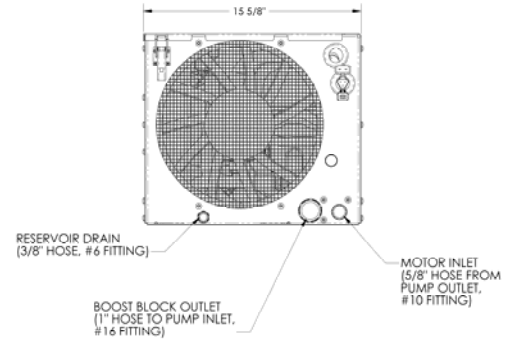
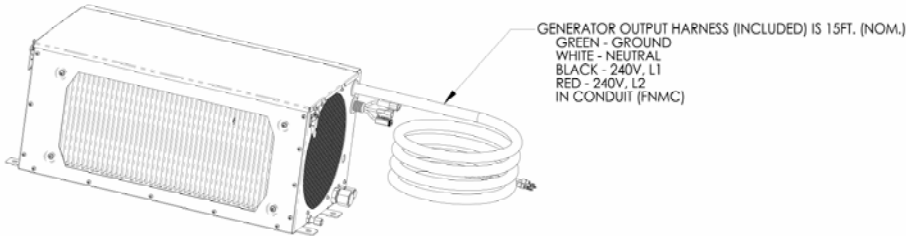
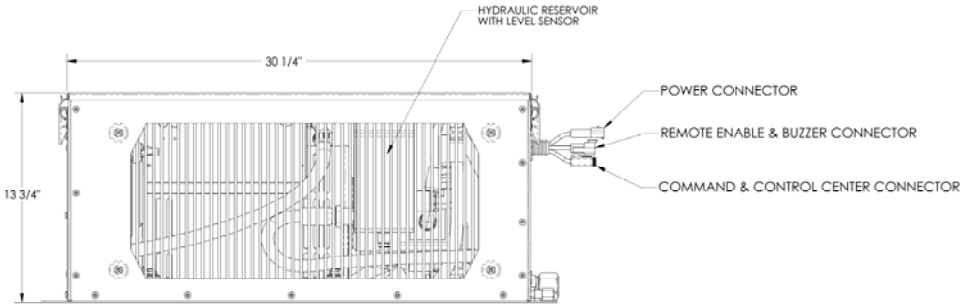
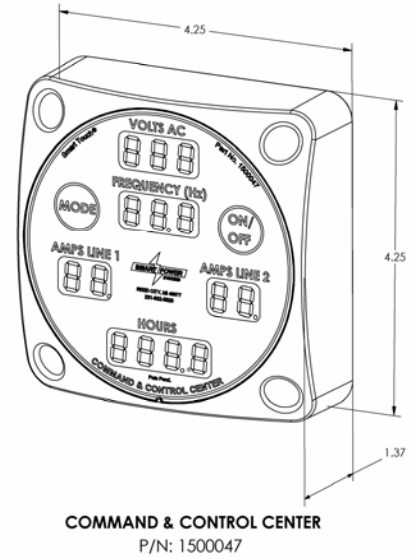
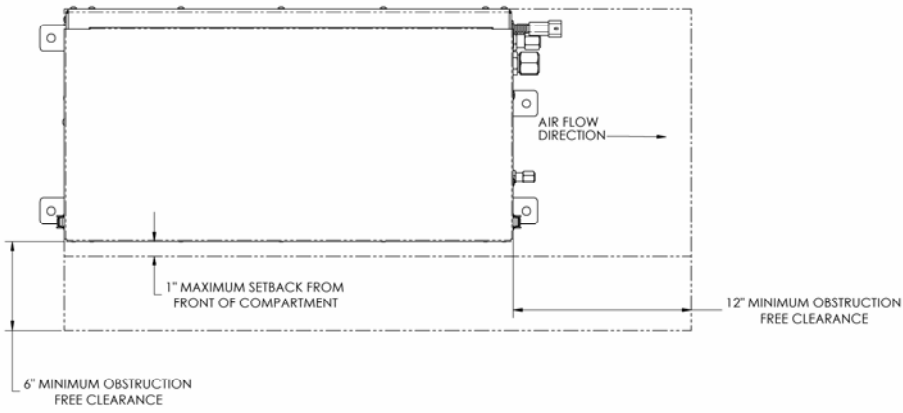

Smart Power System specifications

Model number:	LR-6	LR-8
Power:	6kW	8kW
AC amps:	46/23	66/33
Continuous watts:	5500	8000
Peak watts:	6000	9000
Tray weight:	190 lb.	220 lb.
Hydraulic pump:	23cc	23cc
Pump rotation:	Right hand	Right hand
AC volts:	120/240 VAC (re-connectable to 120 VAC only)	
Frequency:	60 Hertz	
Phase:	Single	
Generator speed:	3600 RPM	
Frame size:	30.25" L x 15.625" W x 13.75" H	
Reservoir:	Integrated within frame	
Hydraulic pump type:	Gear pump	
PSI:	400 to 3200	
GPM:	10	
Required engine speed:	1500-1600 RPM engine speed	
Filtration:	10 Micron	
Fluid:	Dexron III	